

The UNIVER rotary actuator incorporates several technology features which provide a higher degree of accuracy and reliability. The robust mechanical design expands application possibilities within modern day automation.

TECHNICAL CHARACTERISTICS

Working pressure: 1,5 ÷ 10 bar
Ambient temperature: -20° ÷ +80°C
Fluid: filtered air with or without lubrication
Cylinder barrel: aluminium extrusion, internally and externally anodized 15 - 18 microns
Rack backlash recovery
Rotating pinion supported by ball bearings



Theoretical torque at 1 bar

Multiply the value in the table by the operating pressure

Cyl. Ø	32	40	50	63	80	100	125
M: (Nm)	1,2	2,25	3,9	7,3	15,7	26,5	51

Maximum kinetic energy absorbable by cushioning

The adjustment of the rotation angle reduces the effect of cushioning (R12 - R14)

Cyl. Ø	32	40	50	63	80	100	125
E _c (Nm)	1,8	2,5	4,5	8	12	21	36

Magnetic sensor DH- Series (Section accessories see page 2).

Static loads acceptable for the pinion

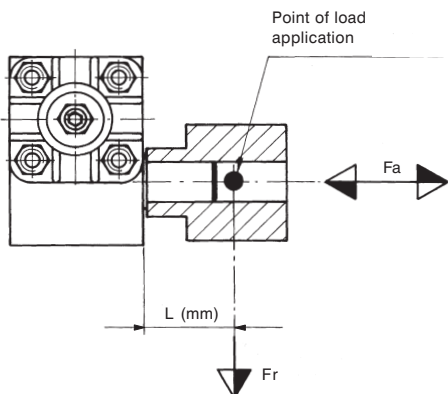

Fa = Axial loads max (N) with Fr = 0

Cyl. Ø	32	40	50	63	80	100	125
Fa	100	100	120	120	200	250	300

Codification Key

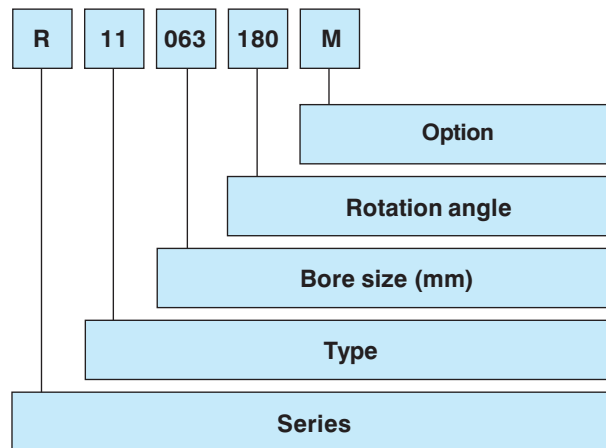

TYPES

- 11 Male pinion without adjustment (positional accuracy ± 3°)
- 12 Male pinion with adjustment ± 5°
- 13 Female pinion without adjustment (positional accuracy ± 3°)
- 14 Female pinion with adjustment ± 5°

BORE

032 - 040 - 050 - 063 - 080 - 100 - 125 mm

ROTATION ANGLE

90° - 180° - 270° - 360°

OPTION

M = Magnetic version

Fr = Radial loads max (N) with Fa=0 based on L protrusion

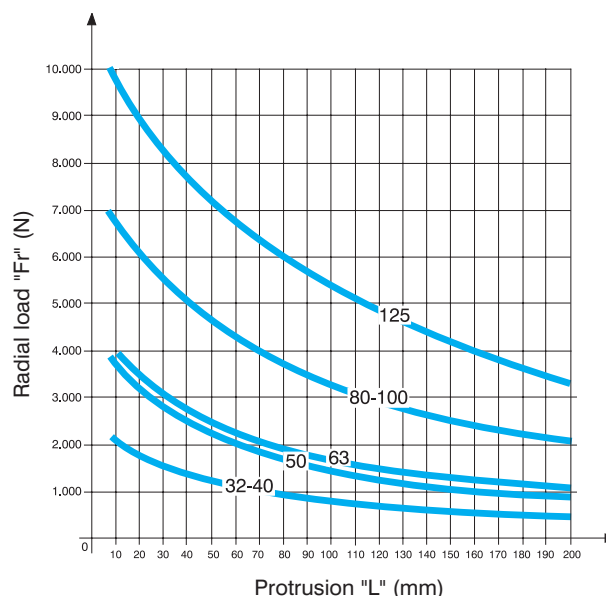

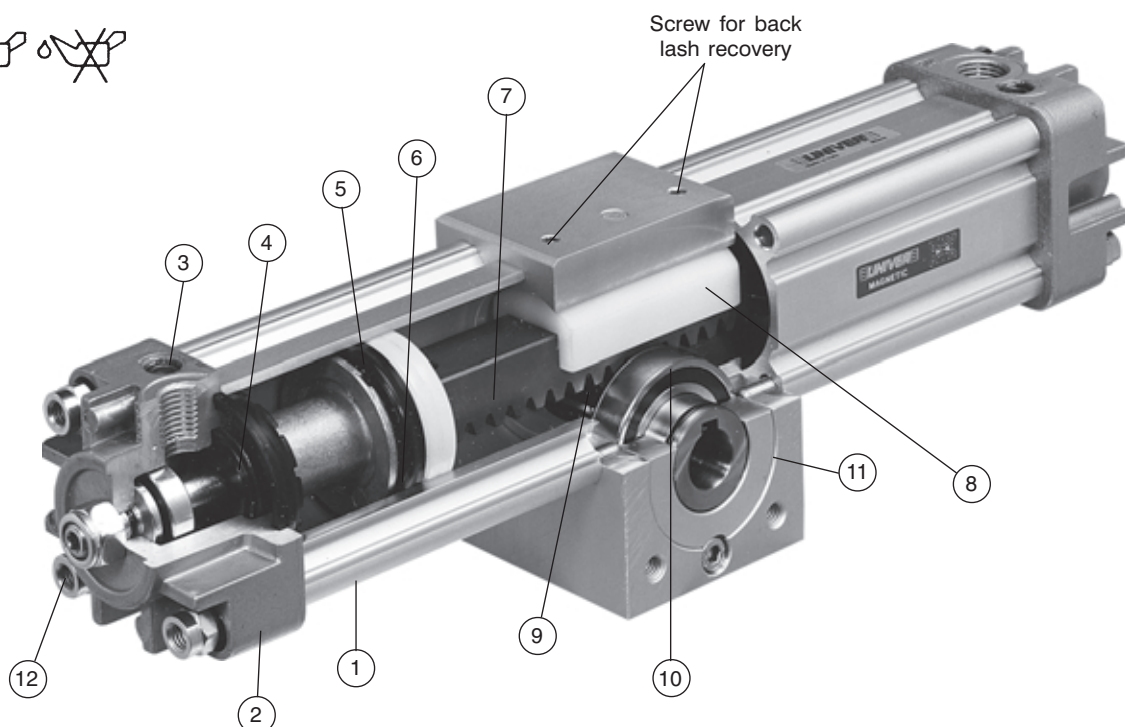
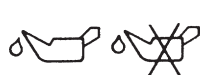

Construction details

- ① Cylinder barrel in extruded aluminium alloy with ribbed design for rigidity and without stagnation points. Internally and externally anodized up to 18 micron.
- ② Light aluminium alloy die-cast end-caps are fixed to the body by means of tie rods and bushings.
- ③ Pneumatic adjustable cushioning provides an efficient piston deceleration.
- ④ Mechanical barrel/end-cap seal.
- ⑤ Aluminium alloy articulated piston and acetalic-resin slide with permanent plastoferrite magnetic ring (upon request).
- ⑥ Piston seals and cushions are made of a wear resistant nitrilic rubber compound, suitable for applications with or without lubrication, the double lip shape allows the constant wear recovery.
- ⑦ Square rack made of stainless steel reduces backlash in the mechanism.
- ⑧ Rack guiding slide with self adjusting backlash.
- ⑨ Pinion of nitrided steel.
- ⑩ Pinion supported by ball-race bearings (bronze/teflon bearing fitted to Ø 32 version).
- ⑪ Anodized aluminium body.
- ⑫ Rotation angle adjustment screw, with a rotation angle $\pm 5^\circ$ Series R12 - 14. (It is advisable not to make adjustments while the cylinder is under pressure)

Rotating cylinders with:

male pinion



female pinion





Basic overall dimensions

Cyl. Ø	A	B	C ±0,1	D	E	F	G	H	I	K	M	N	P	Q	R	S		T	U	V		W	X	Y		Z
																g 6	6			M7	M7			±0,1	H7	
32	48	M6	33	18	G1/8	50	25	46,5	16	71,5	51	50	30	25	5	14	25	16,3	5	25	M5	18	14			
40	54	M6	40	22	G1/4	60	30	54,5	16	82	61	60	30	25	5	14	25	16,3	5	25	M5	22	14			
50	67	M8	50	22	G1/4	70	32,5	60,5	21,5	94	66	65	40	35	6	19	30	21,8	6	30	M6	25	19			
63	78	M8	60	25,5	G3/8	75	37	70,8	27	110	76	75	40	35	8	24	30	21,8	6	30	M8	35	19			
80	97	M10	80	27	G3/8	99	50	93,5	31	142	100	99	50	45	8	28	45	27,3	8	45	M8	50	24			
100	115	M10	80	27,5	G1/2	115	54	99	41	156,5	116	115	50	45	10	38	50	31,3	8	50	M10	60	28			
125	140	M12	90	31,5	G1/2	125	60	118	41	188	141	140	50	45	10	38	60	31,3	8	60	M10	70	28			

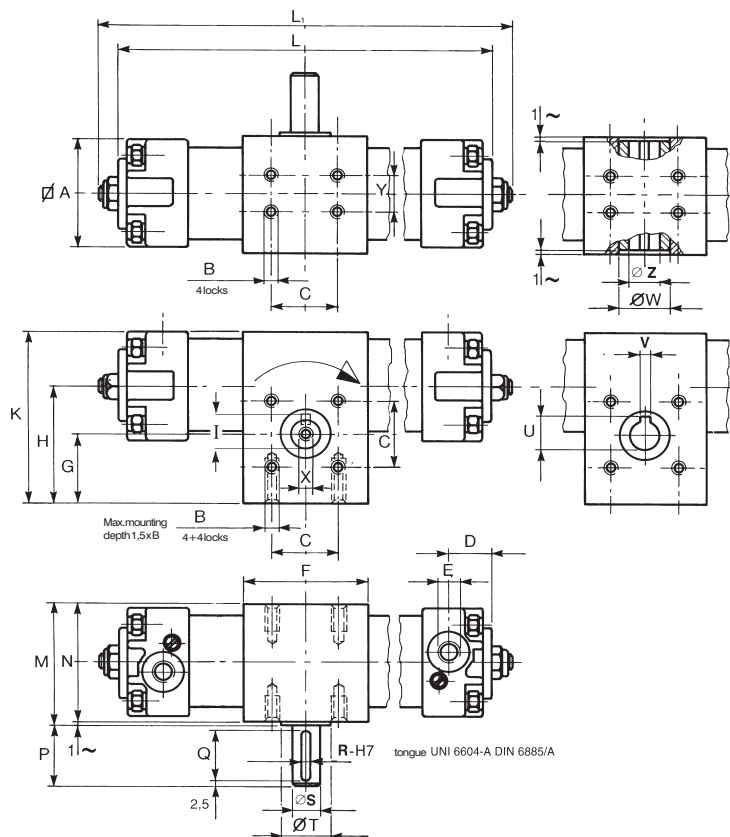

Overall dimensions L-L₁ and weights with standard rotations

L₁ : overall dimensions with stroke regulation (R12 - R14)

L : overall dimensions without stroke regulation (R11 - R13)

Cyl. Ø	Rotation 90°				Rotation 180°				Rotation 270°				Rotation 360°			
	L ₁	L	Mass (kg)		L ₁	L	Mass (kg)		L ₁	L	Mass (kg)		L ₁	L	Mass (kg)	
			Male pinion	Female pinion			Male pinion	Female pinion			Male pinion	Female pinion			Male pinion	Female pinion
32	234	206	1,300	1,200	282	254	1,420	1,320	330	302	1,540	1,440	378	348	1,660	1,560
40	278	246	2,010	1,900	336	304	2,210	2,900	394	360	2,390	2,280	450	418	2,580	2,470
50	308	268	3,070	2,840	372	332	3,340	3,110	436	394	3,610	3,380	498	458	3,880	3,650
63	356	310	4,990	4,640	432	386	5,500	5,170	508	460	6,010	5,700	582	536	6,520	6,230
80	426	376	9,840	9,220	526	476	10,840	10,230	626	574	11,840	11,240	726	674	12,840	12,250
100	456	404	13,650	12,680	564	512	14,860	13,870	672	618	16,070	15,060	778	726	17,280	16,250
125	520	474	23,370	22,220	654	606	25,720	24,520	786	738	28,070	26,820	918	870	30,420	29,120

Overall dimensions with intermediate rotations

Intermediate rotations can be obtained by reducing the length of the right-hand piston housing. For this purpose select the standard model having a rotation degree slightly higher than the one required.

The length dimensions L-L₁ are then reduced in accordance with the following table for each rotation degree.

Cylinders Ø	32	40	50	63	80	100	125
Reduction mm	0,262	0,315	0,350	0,415	0,550	0,594	0,733

The left-hand piston housing maintains standard dimensions $\left(\frac{L}{2}, \frac{L_1}{2}\right)$